

# SPOTTOPS



## FIND A SAFE SPOT POP YOUR TOP

### SPOTTOPS

The SPOTTOPS is a free-standing, mobile, cost-effective solution that provides individuals at schools, colleges and universities, businesses, healthcare facilities, etc. with a highly adaptable protected personal space. SPOTTOPS' unique design provides densification and is ideal for classrooms, reception areas, exchange windows, conference rooms, cafeterias, security checkpoints, wellness stations, waiting areas, dorm study areas, libraries and so much more.

## FEATURES

- Multi-Angle Protection
- Hinged Side Wings
- Protects the Individual—Students, Teachers, Professors, Healthcare Workers, and other Employees
- Multi-Unit Configurations can densify and protect large areas
- Torque Hinges keep Side Wings in place
- 255 Degrees of Pivot
- Handicap Accessible
- Standing or Seated Use for all Height Ranges
- Lockable Caster Wheels for Mobility

## MOUNTING OPTIONS

- Desk or Table Top
- Free Standing or Fixed Mount
- Ceiling Hanging
- Multiple Mounting Holes
- Multiple Hanging Options
- Optional Adjustable Height Mounting Stand

## POST PANDEMIC APPLICATIONS

- Podiums and Lecterns
- Personal Space during Cold and Flu Season
- Workspaces for Open Areas
- Common Areas With or Without Desk or Table Tops



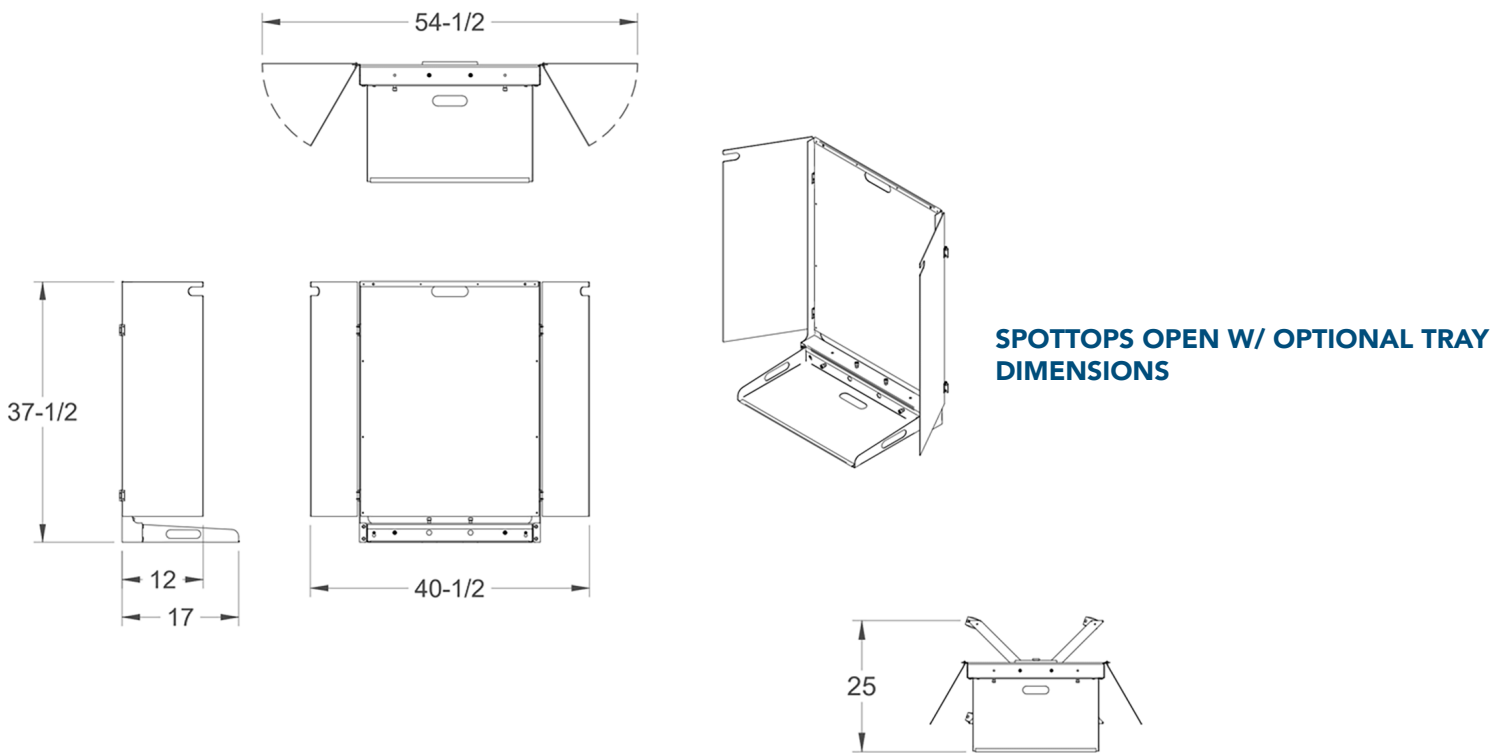

**SPOTTOPS OPEN W/ OPTIONAL TRAY DIMENSIONS**

**SPOTTOPS TOP, STAND, AND TRAY DIMENSIONS**

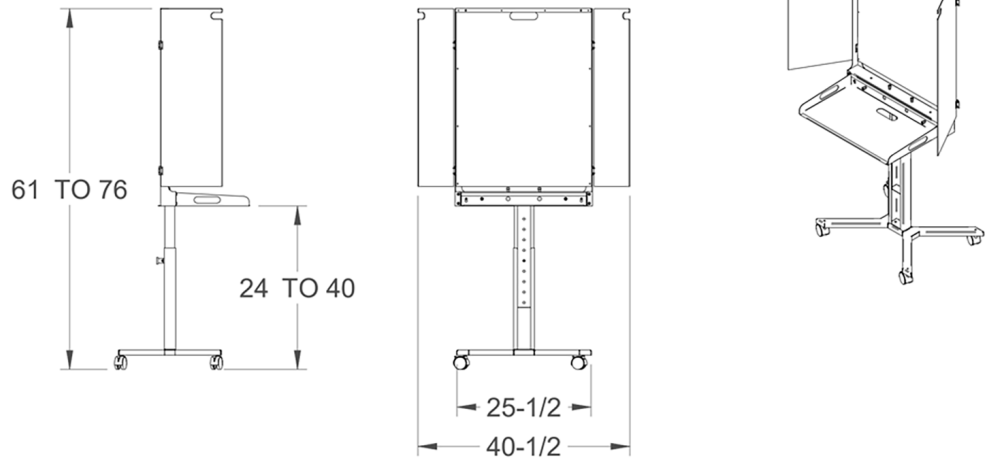

**CONVENIENCE**

- Collapsible and Transportable
- Easily Carried, Moved, and Stored
- Top, Tray and Stand all Collapse into Small Space
- Convenient Built-in Handle combines Top and Tray for Easy Transport

Quantity	Top	Tray	Roller Stand	Desk Mount	Top/Stand	Top/Stand/Tray	Full Kit
1-10 units	\$500.00	\$106.00	\$356.00	\$100.00	\$775.00	\$859.00	\$950.00
11-25 units	\$480.00	\$87.00	\$337.00	\$75.00	\$725.00	\$815.00	\$880.00

*For quantities larger than 25, please request a quote.\**

*Spottops can be custom painted to meet your institution's or business's needs for an additional fee.\*\*  
Pricing subject to change.\*\*\**



# SPOTTOPS



Made in the USA  
SWAM Certified Vendor

CMS SAFETY PRODUCTS

A Division of Custom Manufacturing Services, Inc.

142 Brick St.

Princeton, WV 24740

[safe-d@cmserm.com](mailto:safe-d@cmserm.com)

304.431.7170 Ext. 3246



SCAN ME